

- NOTES:
- Demolish all metal pipe columns and wood posts
 - Provide 3" diameter pipe columns in locations shown and bolt to new footings

LEGEND

-  New Walls
-  Area of structure not in contract except for electrical and plumbing connections, unless noted otherwise

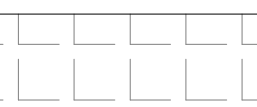
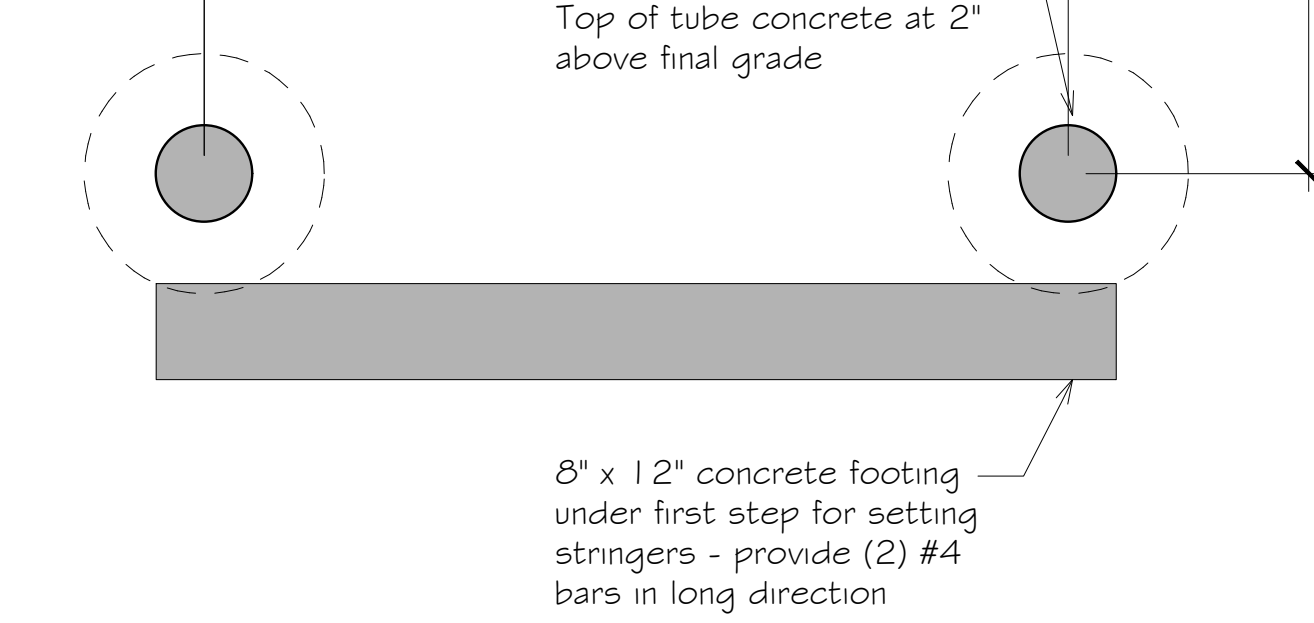
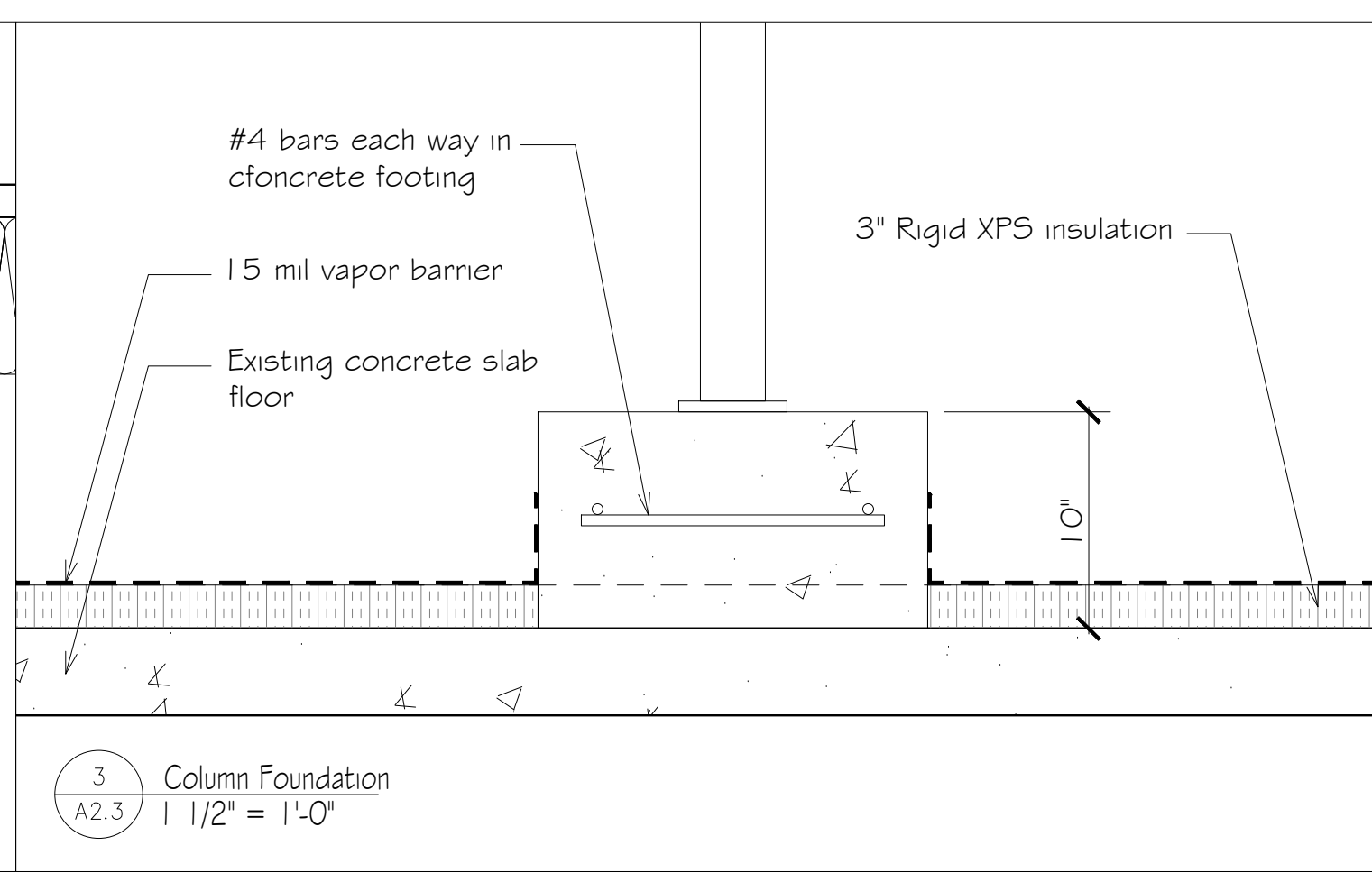
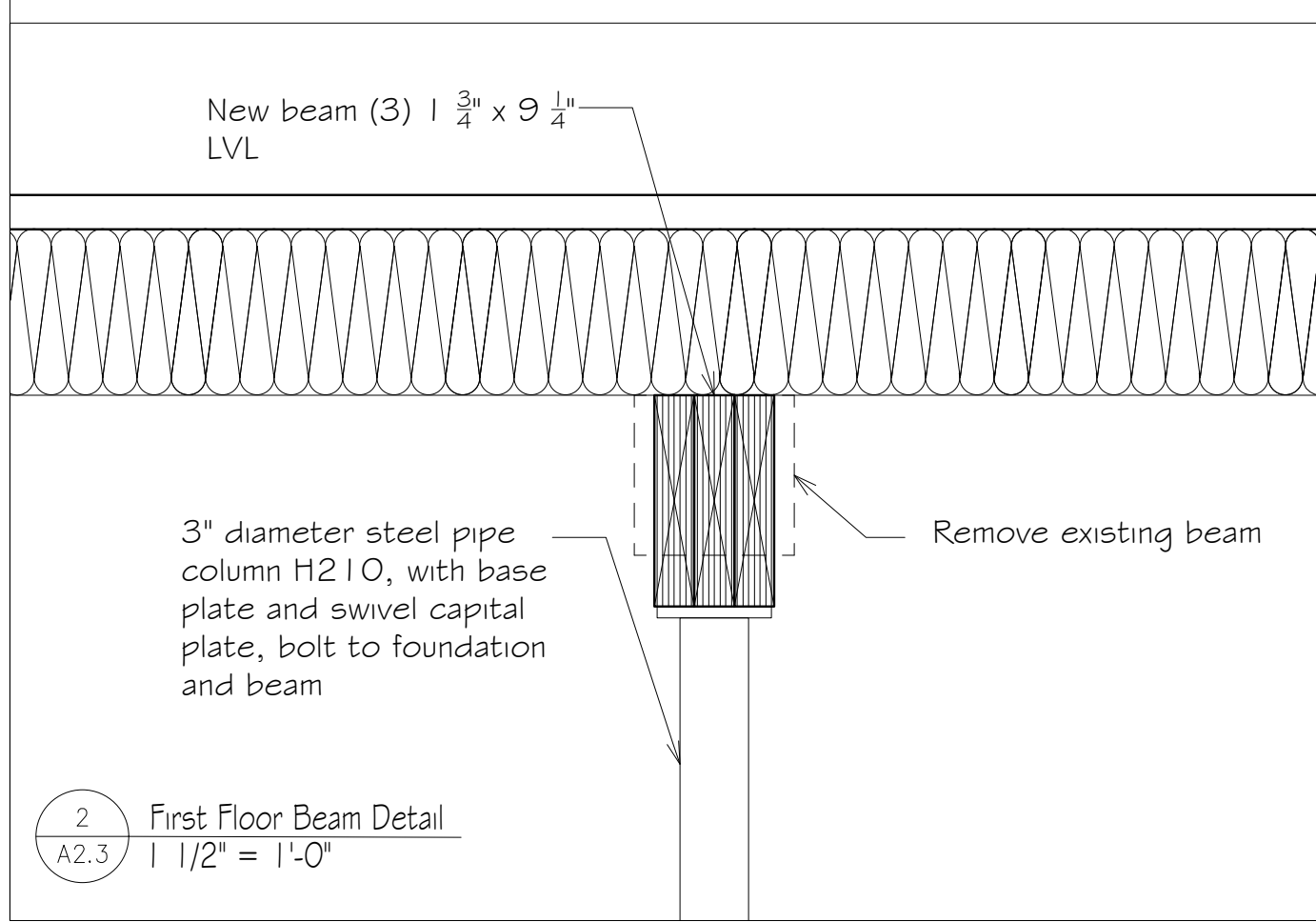
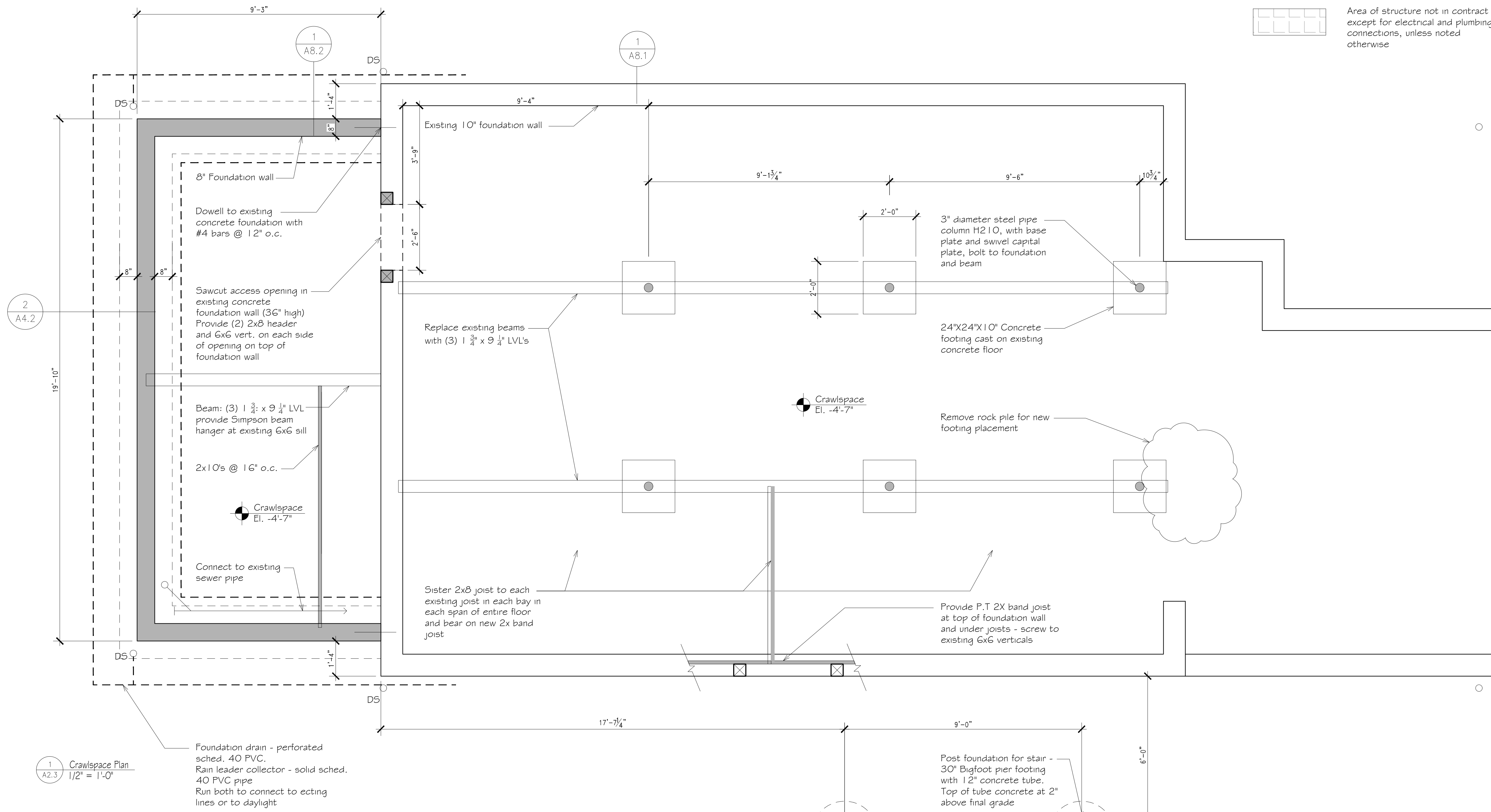

Crawspace Plan

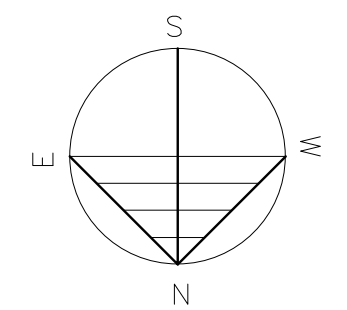

SCALE: AS NOTED

12-4-23

DRAWN BY CHECKED BY

PROJECT NUMBER

DRAWING NUMBER

A2.3